

DOOR LEGEND

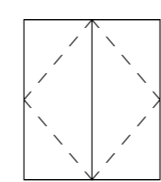

Double-Flush Panel Door 68 x 80



Single-Flush Door 34 x 84

DOOR LEGEND
1/8" = 1'-0"

Door Schedule

Mark	Type Mark	Family	Width	Height	Thickness
6	2	Single-Flush	2' - 10"	7' - 0"	0' - 2"
3	2	Single-Flush	2' - 10"	7' - 0"	0' - 2"
5	2	Single-Flush	2' - 10"	7' - 0"	0' - 2"
7	2	Single-Flush	2' - 10"	7' - 0"	0' - 2"
2	2	Single-Flush	2' - 10"	7' - 0"	0' - 2"
1	2	Single-Flush	2' - 10"	7' - 0"	0' - 2"
4	2	Single-Flush	2' - 10"	7' - 0"	0' - 2"
8	2	Single-Flush	2' - 10"	7' - 0"	0' - 2"
46	2	Single-Flush	2' - 10"	7' - 0"	0' - 2"
47	2	Single-Flush	2' - 10"	7' - 0"	0' - 2"
48	2	Single-Flush	2' - 10"	7' - 0"	0' - 2"
49	2	Single-Flush	2' - 10"	7' - 0"	0' - 2"
50	2	Single-Flush	2' - 10"	7' - 0"	0' - 2"
51	2	Single-Flush	2' - 10"	7' - 0"	0' - 2"
52	2	Single-Flush	2' - 10"	7' - 0"	0' - 2"
53	2	Single-Flush	2' - 10"	7' - 0"	0' - 2"
54	2	Single-Flush	2' - 10"	7' - 0"	0' - 2"
55	2	Single-Flush	2' - 10"	7' - 0"	0' - 2"
56	2	Single-Flush	2' - 10"	7' - 0"	0' - 2"
57	2	Single-Flush	2' - 10"	7' - 0"	0' - 2"
58	2	Single-Flush	2' - 10"	7' - 0"	0' - 2"
59	2	Single-Flush	2' - 10"	7' - 0"	0' - 2"
60	2	Single-Flush	2' - 10"	7' - 0"	0' - 2"
61	2	Single-Flush	2' - 10"	7' - 0"	0' - 2"
11	2	Single-Flush	2' - 10"	7' - 0"	0' - 2"
12	2	Single-Flush	2' - 10"	7' - 0"	0' - 2"
13	2	Single-Flush	2' - 10"	7' - 0"	0' - 2"
10	8	Door-Double-Flush_Panel	5' - 8"	6' - 8"	0' - 2"
9	8	Door-Double-Flush_Panel	5' - 8"	6' - 8"	0' - 2"



Digital Design Graphics Technology
2277 Napa-Vallejo Hwy
Napa, CA 94558



No.	Description	Date

**RODRIGUEZ
NAPA
COMMERCIAL
BUILDING
DOOR SCHEDULE**

Project Number 2022-0031
Date 6-5-2022
Drawn By NRODRIGUEZ
Checked By ELOGAN-SHAH

A601
Scale 1/8" = 1'-0"

LIGHT LEGEND

-  Troffer light
Parabolic 2 x 2
-  Troffer light
Parabolic 2 x 4
-  Round Recessed
Lamp

LIGHTS LEGEND
1/8" = 1'-0"

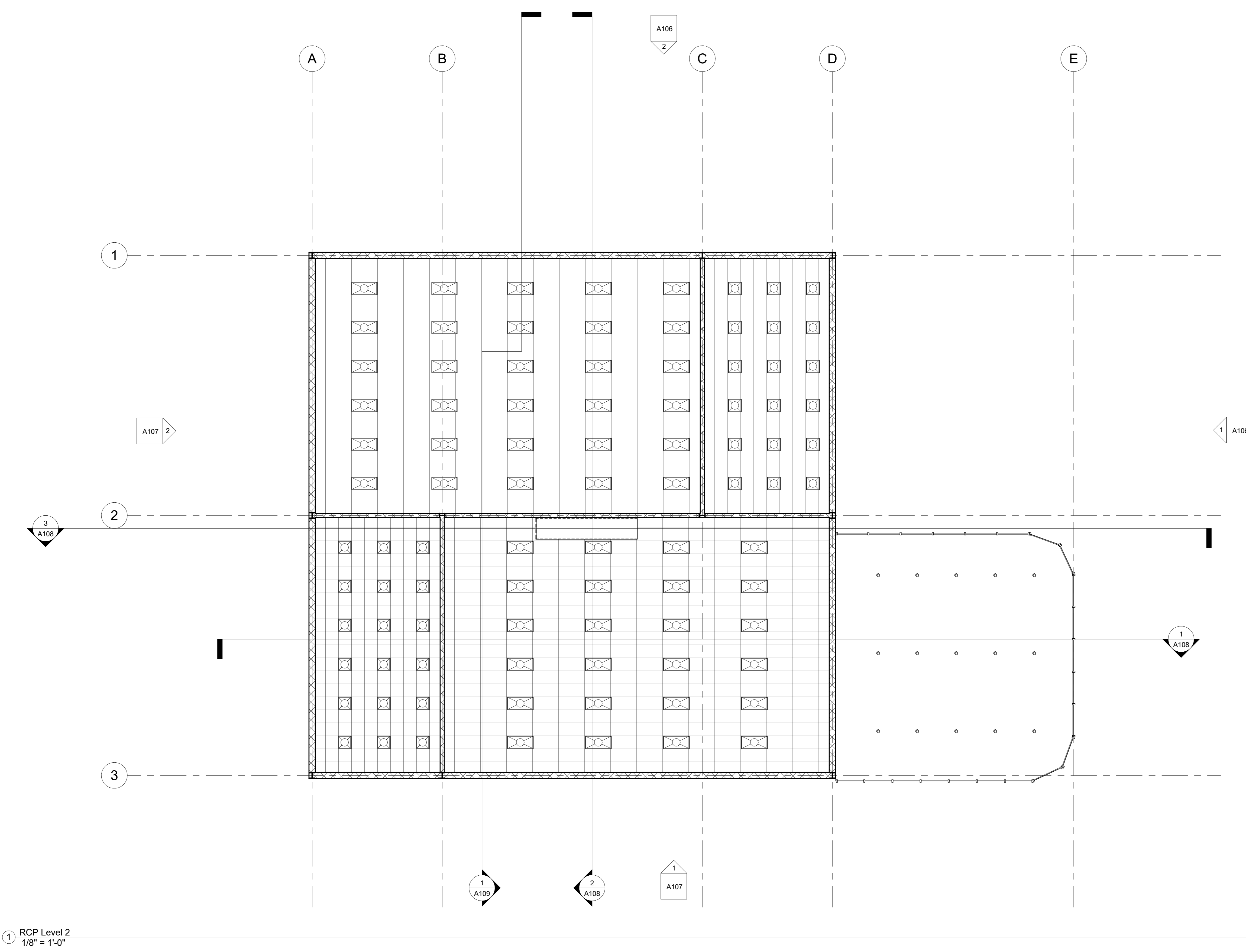

① RCP Level 2
1/8" = 1'-0"

No.	Description	Date



RODRIGUEZ
NAPA
COMMERCIAL
BUILDING
RCP LEVEL 2

Project Number	2022-0031
Date	6-5-2022
Drawn By	NRODRIGUEZ
Checked By	ELOGAN-SHAH

A702

Scale	1/8" = 1'-0"
-------	--------------

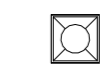
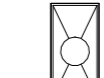
LIGHT LEGEND

-  Troffer light
Parabolic 2 x 2
-  Troffer light
Parabolic 2 x 4
-  Round Recessed
Lamp

 LIGHTS LEGEND
1/8" = 1'-0"



Digital Design Graphics Technology
2277 Napa-Vallejo Hwy
Napa, CA 94558

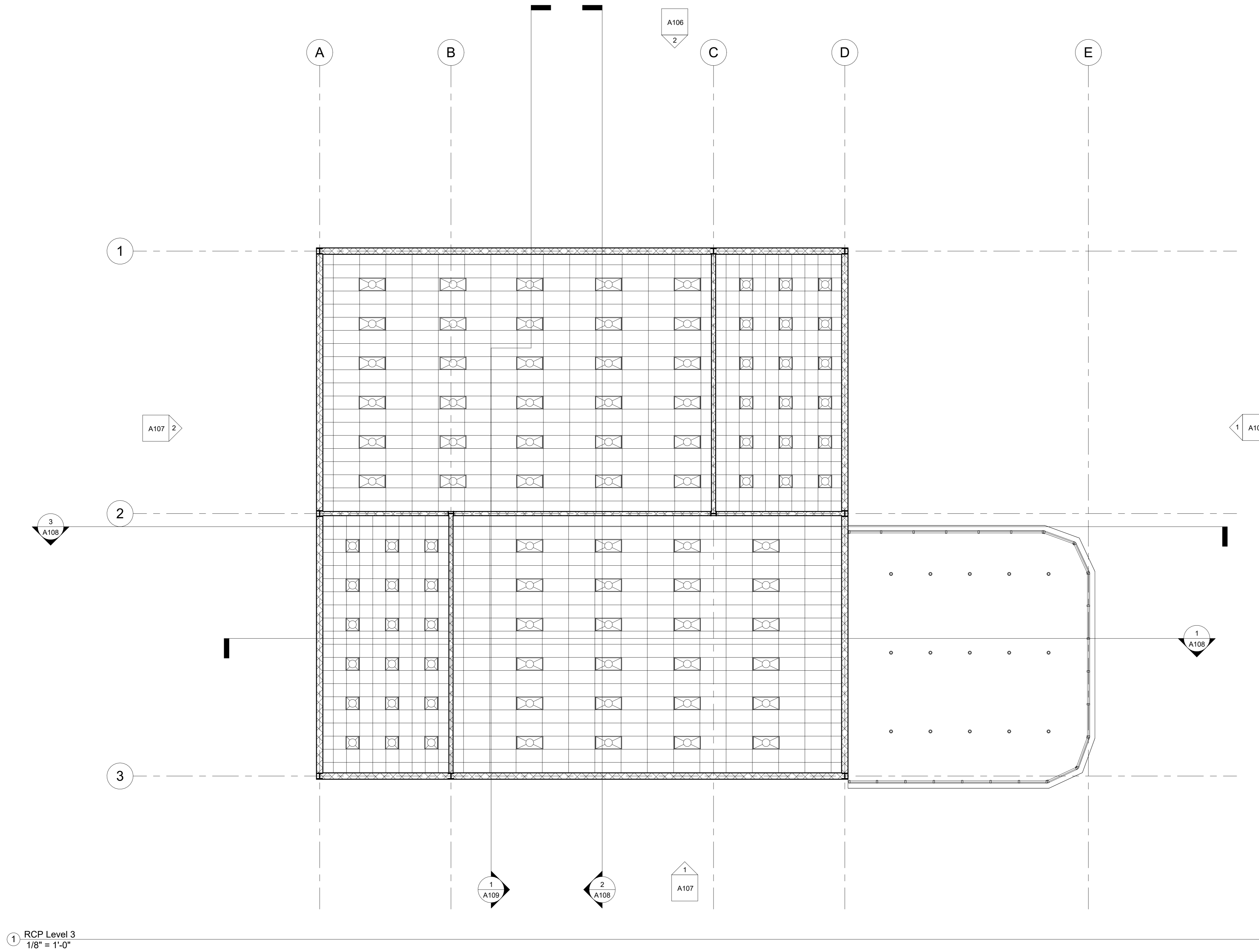

No.	Description	Date

RODRIGUEZ

NAPA COMMERCIAL BUILDING

RCP LEVEL 3

Project Number	2022-0031
Date	6-5-2022
Drawn By	NRODRIGUEZ
Checked By	ELOGAN-SHAH

A703

Scale	1/8" = 1'-0"
-------	--------------

